



Magnum-XD *Extreme Duty* Tarp System

US Patents and Patents Pending

Installation and Owner's Manual

For assistance; call 252-291-2141 or
sales@obriantarping.com

ATTENTION INSTALLER: DO NOT DISCARD!

Please forward to customer when unit is delivered
Hang driver operation tag in cab around hoist controls

Warning: if incorrectly used, this equipment can cause injury!

July 2019

Table of Contents

<u>Section</u>	<u>Description</u>	<u>Page</u>
1	Operation	2
2	Overview	3-4
3	Magnum-XD Packing list	5
4	Gantry Installation	6-7
5	Pivot Assembly Installation	8
6	Side Arm Installation	9-10
7	Plumbing	11-15
8	Maintenance	15
9	Tarp Replacement	16-17
10	Warranty	18

MAGNUM-XD TARP SYSTEM OPERATION

TO COVER:

1. Rotate lower arms and extend upper arms to raise roller up between cab and container
2. (OPTIONAL) Raise cradle above front of container
3. Once the roller is past the front of the container, continue to hold joystick in the covering direction and cover container.
4. Position the roller so it will REST ON THE TOP REAR EDGE OF THE CONTAINER BUT BELOW 13'6". POWER DOWN THE ROLLER AGAINST THE TAILGATE. This helps to keep the roller from bouncing up and down while going down the road.
5. Flip the tarp's side flaps out and secure them as needed.
6. (Optional) Lower gantry to just below container edge

TO UNCOVER:

1. Un-secure the side flaps.
2. (Optional) Raise the cradle over the front edge of the container.
3. Rotate the side arms forward to clear the front top edge of the container while also rotating the upper arms to set the roller in the bottom of the cradle.
4. (Optional) Lower gantry
5. POSITION THE ROLLER SO IT IS RESTING ON THE BOTTOM OF THE CRADLE! This keeps the arms from bending downward.

MAGNUM SCHEMATIC

APRIL 2004-CURRENT

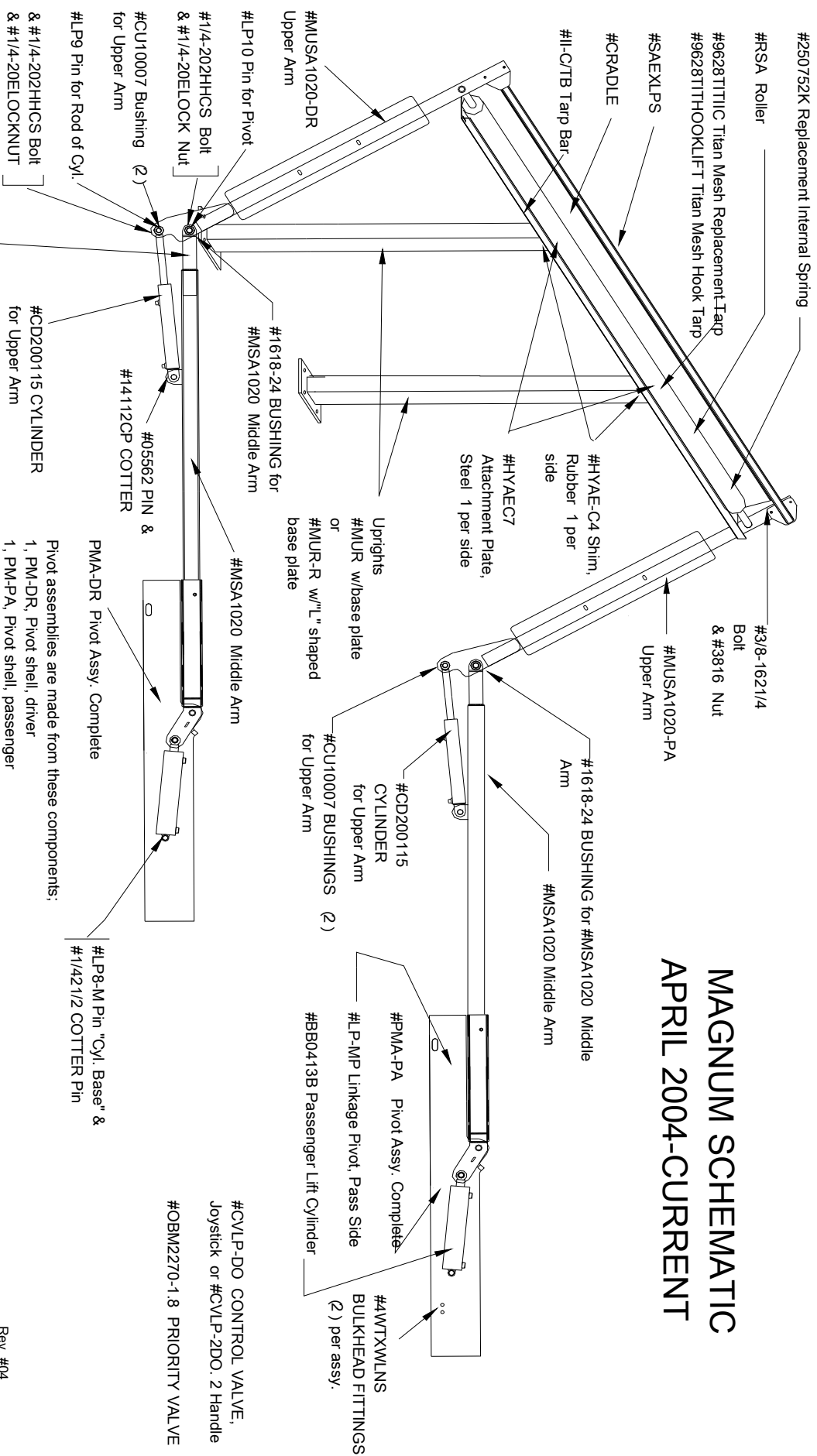

#250752K Replacement Internal Spring

#RSA Roller

#9628TITIC Titan Mesh Replacement Tap

#9628TITHOOKLIFT Titan Mesh Hook Tap

#SAEXLPS

#CRADLE

#11-C/TB Tarp Bar

#MUSA1020-DR Upper Arm

#LP10 Pin for Pivot

#1/4-202HHCS Bolt & #1/4-20ELOCK NUT

#CU10007 Bushing (2) for Upper Arm

#LP9 Pin for Rod of Cyl.

#CD200115 CYLINDER for Upper Arm

#05562 PIN & #14112CP COTTER

#MUSA1020 Middle Arm

#1618-24 BUSHING for Middle Arm

#HYAEC7 Rubber 1 per side

#HYAEC7 Attachment Plate, Steel 1 per side

#3/8-1621/4 Bolt & #3816 Nut

#MUSA1020-PA Upper Arm

#1618-24 BUSHING for #MUSA1020 Middle Arm

#MUSA1020 Middle Arm

#CD200115 CYLINDER for Upper Arm

#MUR-R w/"L" shaped base plate

#CU10007 BUSHINGS (2) for Upper Arm

#PMA-PA Pivot Assy. Complete

#LP8-M Pin "Cyl. Base" & #11/421/2 COTTER PIN

#BB0413B Passenger Lift Cylinder

#4WTXWLNS BULKHEAD FITTINGS (2) per assy.

#CULP-DO CONTROL VALVE, Joystick or #CULP-2DO, 2 Handle

#OBM2270-1.8 PRIORITY VALVE

- Pivot assemblies are made from these components:
- 1, PM-DR, Pivot shell, driver
 - 1, PM-PA, Pivot shell, passenger
 - 1, LP-MD for Driver side or LP-MP for Pass. side
 - 2, 1618-24 Bushings for Shaft in Linkage Pivot
 - 1, LP14-M Pin for attaching linkage pivot to pivot shell
 - 1, 1/4-2034HHCS bolt to anchor LP14-M & 1/4-20ELOCKNUT
 - 2, CP Plastic Plugs to cover holes
 - 2, CU10007 Bushings for linkage at rod end
 - 1, LP7-M Pin attaches linkage to rod of cyl.
 - 1, 1/4-20234HHCS Bolt & 1, 1/4-20ELOCKNUT
 - 1, BB0412B Cylinder for Dr. side
 - 1, BB0413B Cylinder for Pass. Side

- Rev. #04
- 9-04-08
- Rev#05
- 9-11-14
- Rev#06
- 7-26-19

MAGNUM-G SCHEMATIC APRIL 2004-CURRENT

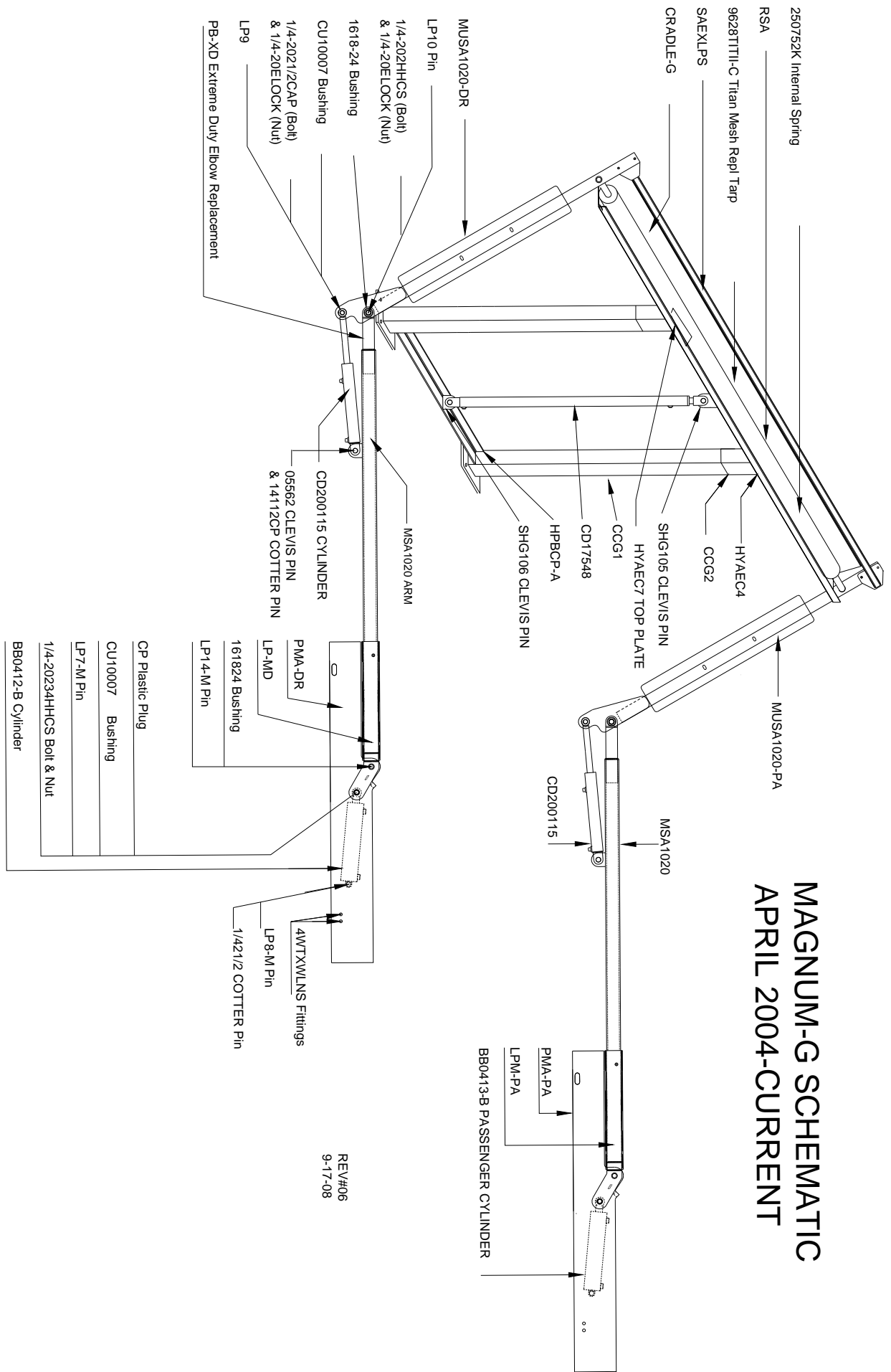

REV#06
9-17-08

Magnum-XD Crate Contents

Quantity	Part Number	Description
4	L-Bracket	2 ½" x 36" Mounting Brackets
8	SF4	Gussets for Brackets
1	PMA-DR	Pivot Modular Assy.-Driver's Side
1	PMA-PA	Pivot Modular Assy.-Pass Side
2	MSA-1020	Lower Side Arms, 2"x3" tubing
1	MUSA1020-DR	Upper Side Arm-Drivers Side
1	MUSA1020-PA	Upper Side Arm-Pass Side
2	MUR	Gantry Uprights
1	RSA w/Tarp	Roller with tarp attached
1	CRADLE	Cradle
2	CD200115	Upper Arm Cylinders
1	SAEXLPS	Stabilizer Bar
4	JF038	Steel Hydraulic Lines
1	HOSEKIT-M	Hose Kit, Magnum-XD
1	SPK-M	Magnum Small Parts Kit
1	II-C/TB	Tarp Bar

Magnum-XDG Crate contents

Quantity	Part Number	Description
4	L-Bracket	2 ½" x 36" Mounting Brackets
8	SF4	Gussets for Brackets
1	PMA-DR	Pivot Modular Assy.-Driver's Side
1	PMA-PA	Pivot Modular Assy.-Pass Side
2	MSA-1020	Lower Side Arms
1	MUSA1020-DR	Upper Side Arm-Drivers Side
1	MUSA1020-PA	Upper Side Arm-Pass Side
2	CCG1	Gantry Uprights
2	CCG2	Gantry Inserts
1	RSA w/Tarp	Roller with tarp attached
1	CRADLE-G	Cradle with Cylinder Mount
2	CD200115	Upper Arm Cylinders
1	SAEXLPS	Stabilizer Bar
4	JF038	Steel Hydraulic Lines
1	HOSEKIT-M	Hose Kit , Magnum XD
1	HOSEKIT-G	Hose Kit-Adjustable Gantry
1	SPK-MG	Magnum-XDG Small Parts Kit
1	II-C/TB	Tarp Bar
1	HPBCP-A	Gantry Cylinder Mount w/Clevis
2	1x52	1" x 52" Gantry Cross Braces
1	CD17548	Gantry Cylinder

GANTRY INSTALLATION

1. Check for clearance between cab, exhaust, and hoist.
2. You will need a minimum of 7" clearance between the front of the hoist and back of the cab to mount the gantry.
3. Position the MUR's on top of the chassis, flex U-bolts apart, slide in from bottom of chassis into mounting plate holes, and attach the 5/8" U-bolts with the 5/8" nuts and lock washers. Be sure to have the gussets at the bottom of the MUR's parallel with the chassis and not perpendicular. If you are unable to use the U-bolts, then a chassis bridge will need to be fabricated for gantry attachment. (Not Provided)
4. The closer the gantry is to the cab the easier it will be to operate the arms in front of the container. ***Note-leave at least one (4") inch of clearance between cab and gantry.**
5. Measure the distance from hoist to gantry. Make sure both gantry legs are the same distance from the hoist and plumb. Tighten down the U-bolts, making sure that the gantry legs remain level front to rear and side to side.
6. Install the cradle on top of the gantry legs using the 4, 1/2" x 1 3/4" bolts. **Insert the rubber shims between cradle and gantry uprights.** *These shims are needed to allow for chassis flex.* Be sure to mount the cradle with the 1/2" bolts and steel shims through the top and the locknuts on the bottom. Do not over-torque mounting bolts and squish out bushing. Over-torquing bolts will cause cradle to crack and is not warranty
7. Place roller assembly into the cradle with the end marked **PASSENGER SIDE and TORQUE SHAFT** on the **PASSENGER SIDE**. Center the tarp and then bolt the tarp bar to the **INSIDE** of the cradle with the 5/16" x 2" bolts and locknuts. (See Diagram)
8. **NOTE:** The shaft end on the passenger side has a **FLAT** spot for attaching the tensioning wheel to. If the flat spot is on the Driver's side, your roller is on backwards

ADJUSTABLE GANTRY INSTALLATION

1. Check for clearance between cab, exhaust, and hoist.
2. You will need a minimum of 7" clearance between the front of the hoist and back of the cab to mount the gantry.
3. Position the CCG1 gantry bases on top of chassis, flex U-bolts apart, slide in from bottom of chassis into mounting plate holes, and attach the 5/8" U-bolts with the 5/8" nuts and washers. Be sure to have the gussets at the bottom of the MUR's parallel with the chassis and not perpendicular. If you are unable to use the U-bolts, then a chassis bridge will need to be fabricated for gantry attachment. (Not Provided)
4. The closer the gantry is to the cab the easier it will be to operate the arms in front of the container. ***Note-leave at least one inch (4") of clearance between cab and gantry.**
5. Measure the distance from hoist to gantry. Make sure both gantry legs are the same distance from the hoist and plumb. Tighten down the U-bolts, making sure that the gantry legs remain level front to rear and side to side
6. Insert the CCG2, gantry inserts into the CCG1 gantry bases.
7. Mount cradle-G on top of gantry inserts using the 4, 1/2" x 1 3/4" bolts. **Insert the rubber shims between cradle-G and gantry inserts.** *These shims are needed to allow for chassis flex.* Be sure to mount the cradle with the 1/2" bolts and steel shims through the top and the nuts with lock washers on the bottom. Do not over-torque mounting bolts and squish out bushing. Over-torquing bolts will cause cradle to crack and void warranty
8. Place roller assembly into the cradle with the end marked **PASSENGER SIDE and TORQUE SHAFT** on the **PASSENGER SIDE**. Center the tarp and then bolt the tarp bar to the **INSIDE** of the cradle with the 5/16" x 2" bolts and locknuts. (See Diagram)
9. **NOTE:** The shaft end on the passenger side has a **FLAT** spot for attaching the tensioning wheel to. If the flat spot is on the Driver's side, your roller is on backwards.
10. Attach the CD17548 cylinder to the Cradle-G clevis with the supplied clevis pin. Attach the base of the cylinder to the female clevis with the supplied clevis pin. Measure the distance between the gantry legs at the cylinder base clevis pad. Cut the HPBCB-A cylinder mounting bracket to fit this dimension. Weld the HPBCP-A angle to the gantry legs, making sure that the HPBCP-A angle is level and plumb with the truck.

Make sure that the gantry legs are level and plumb, weld the 1X2 cross braces to the gantry bases in a criss-cross pattern. This will give the gantry additional bracing for raising and lowering the cradle.

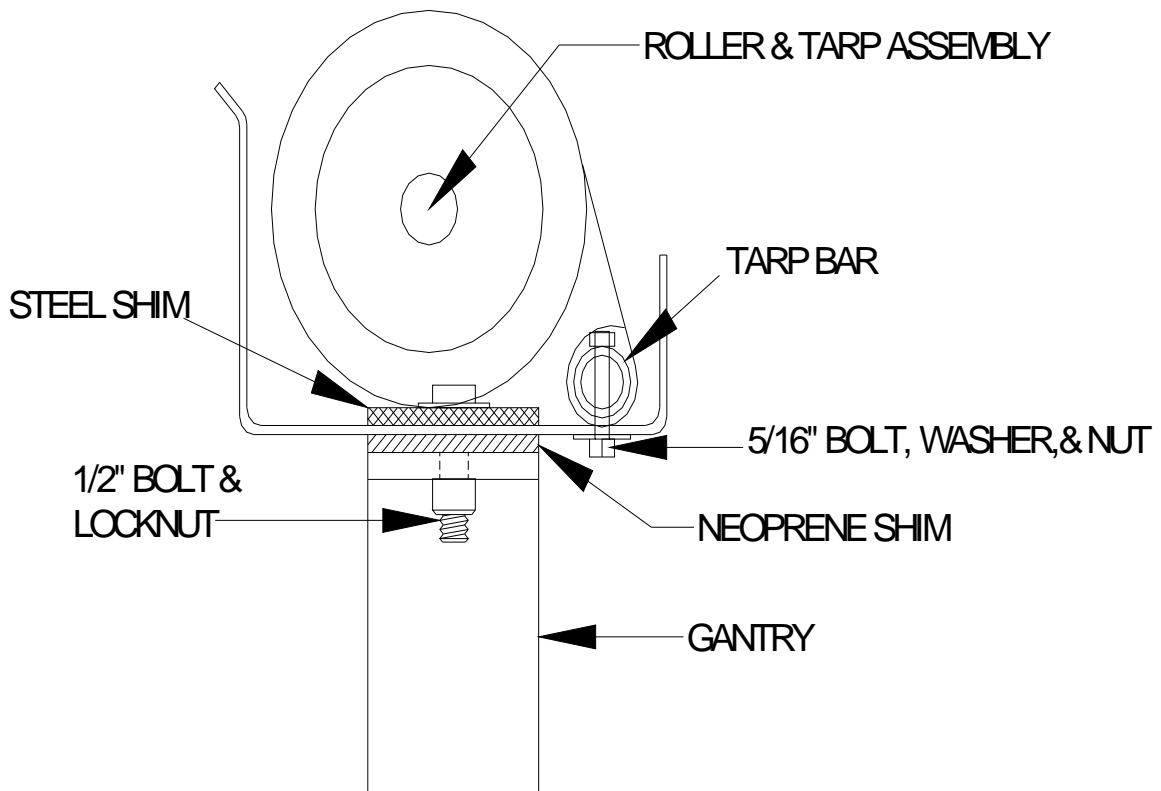
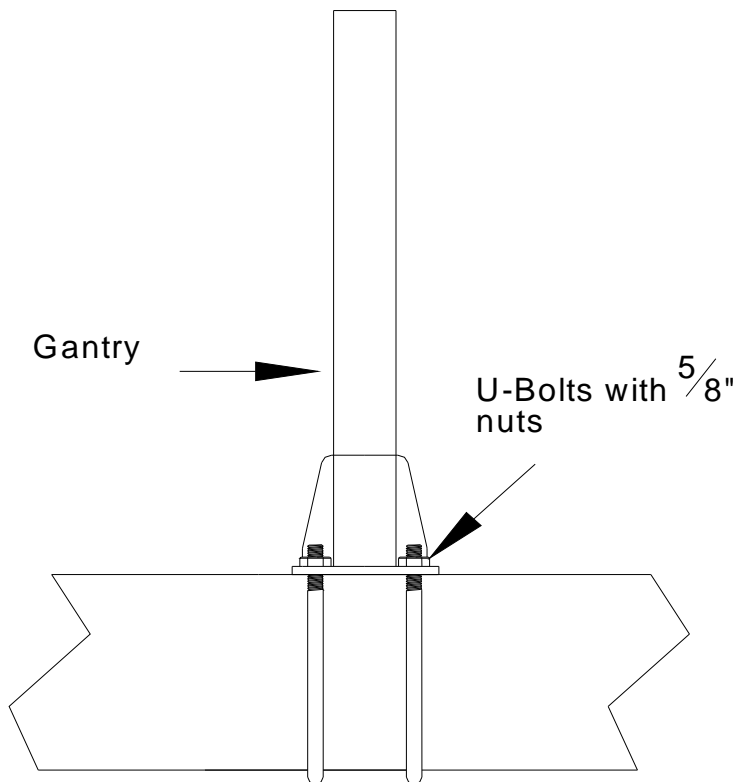

PIVOT ASSEMBLY INSTALLATION

1. **Federal D.O.T. allows for 108" MAXIMUM overall width for safety devices. Therefore maximum width for the Magnum-XD Tarp System must not exceed 108" overall width.** This includes any bolts, nuts, hydraulic fittings, etc. Check with your state and local D.O.T. to determine what standards may apply in your area!
2. For example, if the hoist is 35 ½" wide then the following formula will give you your maximum overall width.

$$108'' - 35 \frac{1}{2}'' = 72 \frac{1}{2}''$$

$$72 \frac{1}{2}'' / 2 = 36 \frac{1}{4}'' \text{ maximum width from hoist for each side}$$

O'Brian Tarping Systems recommendation would be 36" maximum overall width for each side

3. PIVOT POINT FORMULA EXAMPLE

Take the length of your longest box (22'-24') and add the length from the front of the box to the center of the gantry uprights (example 1') then divide by two.

$$(22'6'' + 1' = 23'6'', 23'6'' / 2 = 11'9'' \text{ or } 24'6'' + 1' = 25'6'', 25'6'' / 2 = 12'9'')$$

Your pivot point is now 11'-9" or 12'-9" from the center of your gantry uprights to the pivot center of your modular assembly. Measure back along the hoist from the center of the gantry to the pivot point number and make a mark on the hoist. Using a square, make a mark down the hoist and out over the fenders to match up with the pivot assembly.

Note: Average pivot points fall between 11'-9" and 12'-9"; depending on container length of 22' – 24' and the distance between container and Gantry.

4. The Modular pivot assemblies are side sensitive; bulkhead fittings and slotted opening go to the inside facing the hoist. The pivot modules must be level front to rear, side-to-side, and parallel to the hoist.
5. As a general rule, mount the module as low as possible to clear the container and high enough to change the tires.

(Minimum tire clearance is 2" from bottom of module to top of tire!!)

6. Use the supplied 2 ½" x 2 ½" "L" brackets for mounting the module. You may have to cut either length to get the module level front to rear and side to side. **DO NOT WELD TO THE CHASSIS!! THERE MUST BE A PLATE BOLTED TO THE CHASSIS TO WELD TO.**
7. Install 1 of the supplied "L-Brackets" in front of the first drive axle and one in between the first and second drive axle. Make sure that it is level front to rear and side to side. Do this for each side

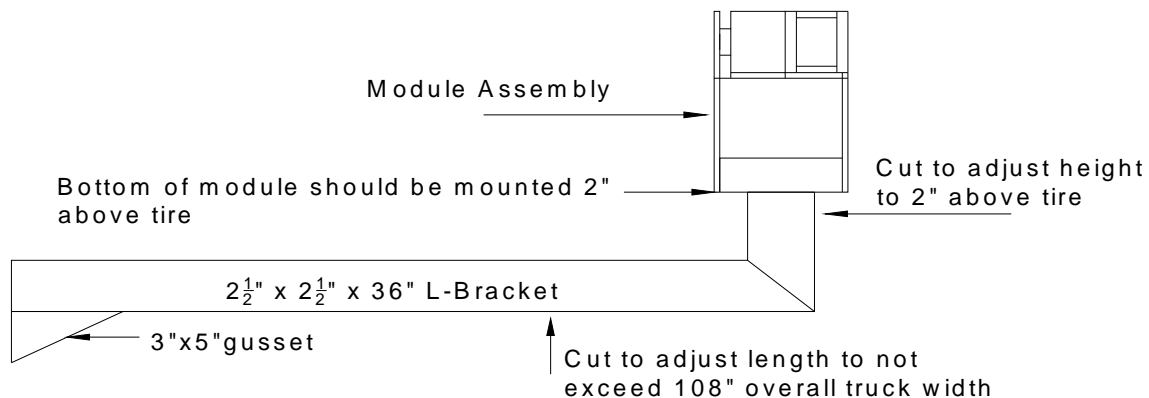

8. Once all 4 L-Brackets are welded and gusseted, position the stabilizer bar on top of the hoist over the first drive axle. Measure down to the top of the tire and then subtract 2". Now measure down to each vertical on the L-Brackets and make a mark at the tire height less 2". For example, the measurement down to the top of the tire is 9". Now subtract 2" from 9" and you arrive at 7". Measure down to each vertical and make a mark at 7" and cut off the vertical at the 7" point. Now the mounting point is level for the pivot modular assembly at all 4 L-Brackets.
9. Make a mark on each pivot assembly on the side closest to the chassis at the main pivot point down to the bottom of the assembly. The main pivot point is where the offset linkage assembly pivots around the highest 1" pin.
10. Lift the PMA-DR pivot assembly and position onto the Driver's side set of L-Brackets. Slide the PMA-DR forward or backwards in order to line up the line on the pivot assembly with the line on the fender from Step 3
11. Using a tape measure, measure out from the hoist to the outside edge of the pivot assembly at the front and the rear. Slide each end out to the number found in step 2 (on average, 36" for each side).
12. Remove the bulkhead caps from the bulkhead fittings to allow you to freely move the offset linkage. Rotate the offset linkage to where it is sticking straight up
13. Attach a level to the offset linkage that is sticking straight up. Push or pull the offset linkage to or from the chassis until the offset linkage is level side to side. Once level, hard tack the pivot assembly to the L-Brackets and double check your previous measurements to make sure that the pivot assembly is level front to rear, side to side and parallel to the hoist.
14. Once your measurements have been double checked, firmly weld together all joints and repeat steps 10-13 for the Passenger side.

SIDE ARM INSTALLATION

1. Slide the lower arm (MSA1020) into the offset linkage mounted in each pivot modular assembly
2. Slide the upper arm (MUSA1020-PA, MUSA-1020-DR) onto the RSA shaft. The MUSA1020-DR goes on the Driver's side and the MUSA1020-PA goes onto the Passenger side.
3. Slide each lower arm (MSA1020) out AND rotate the upper arm around so that the pivot holes are aligned.

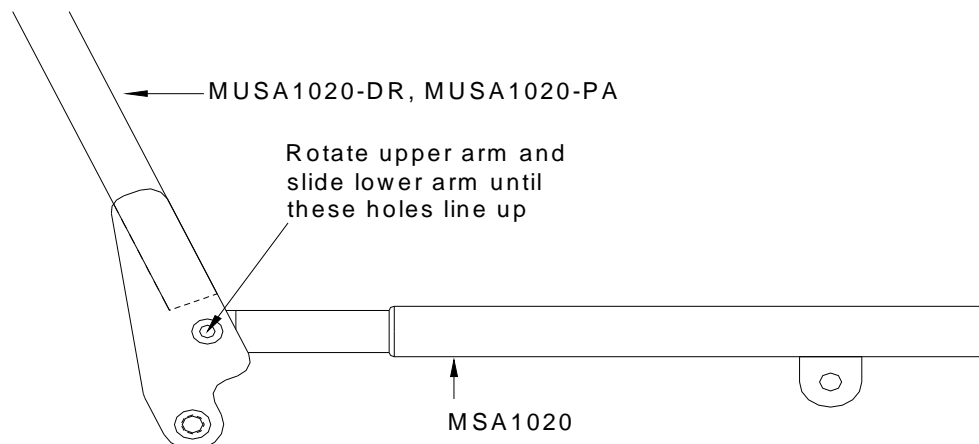

4. Attach the lower arm to the upper arm using the 1"x3" steel pin with a ¼" hole drilled on one end. Secure the pin to the arm with the ¼" x 2" bolt and locknut.
 - a. Lubricating the pin and bushing material with WD-40 or similar will make assembly MUCH easier
5. **Make sure that the lower arms are level. Slide the lower arm in or out of the linkage assembly to accomplish this.** Once level, measure the distance from the elbow pivot to the front edge of the linkage assembly and duplicate on the other side.
6. Drill a ½" hole in the lower arm using the existing ½" hole in linkage assembly as a guide and bolt the lower arm to the linkage assembly. Secure the lower arm with a ½" x 3 ½" bolt and locknut. Repeat for the other side.
7. Install the CD20011.5 elbow cylinder to each lower arm using the 1" x 2" pin with a washer welded to it. Install the pin through the clevis mount of the cylinder through the ¾"x3" tombstone mounted under the arm. Secure the pin with a ¼" cotter pin. **This is the ONLY spot where a cotter pin is used!**
8. Using one of the long zip ties, rotate the arm cylinder up against the arm and wrap the tie around the arm and the cylinder rod to hold the cylinder in position. Repeat for both sides.
9. Place enclosed tarp tensioning wheel on passenger side roller spring shaft. Torque set screw against the flat side of RSA shaft. If the flat spot is on the Driver's side, you have the tarp roller on backwards.
10. Install the 5/16" x 1-3/4" bolt and locknut through the passenger side upper arm (MUSA1020-PA) attaching the arm to the tarp roller. You may have to turn the wheel in order to line up the holes
11. Torque the wheel 10 turns clockwise **FROM THE PASSENGER SIDE**. Keep turning the wheel until the holes in the arm lineup with the holes in the roller on the driver's side. Finish by placing a 5/16" x 1 ¾" bolt through roller shaft and upper arm on Driver's side and securing with the 5/16" locknut

****Failure to install the bolt on the driver's side will cause the ratchet and pawl mechanism to fail, not warranty****

12. Install the stabilizer bar (SAEXLPS) between the upper arms using the (4) 3/8" x 2 ¼" bolts and locknuts. Make sure that the stabilizer bar offset is facing toward the rear. You may have to push or pull the elbows towards the chassis in order to install the stabilizer bar

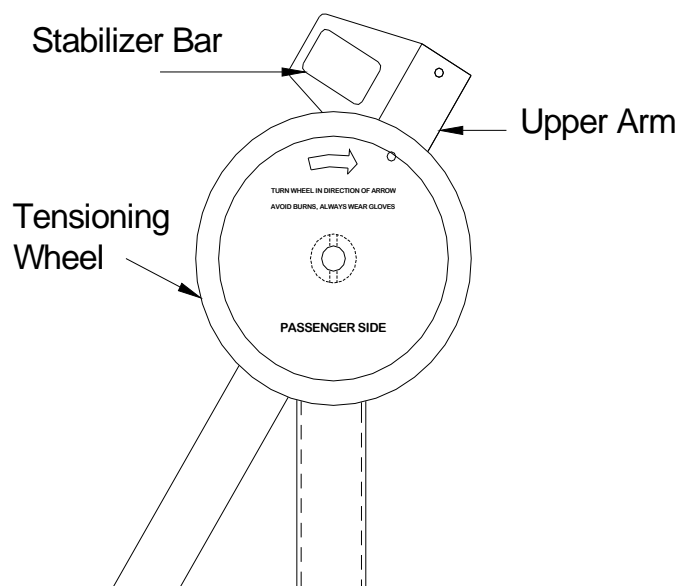

MAGNUM-XD PLUMBING SCHEMATIC

Valve & hose configuration will vary with installation, shown as an illustration

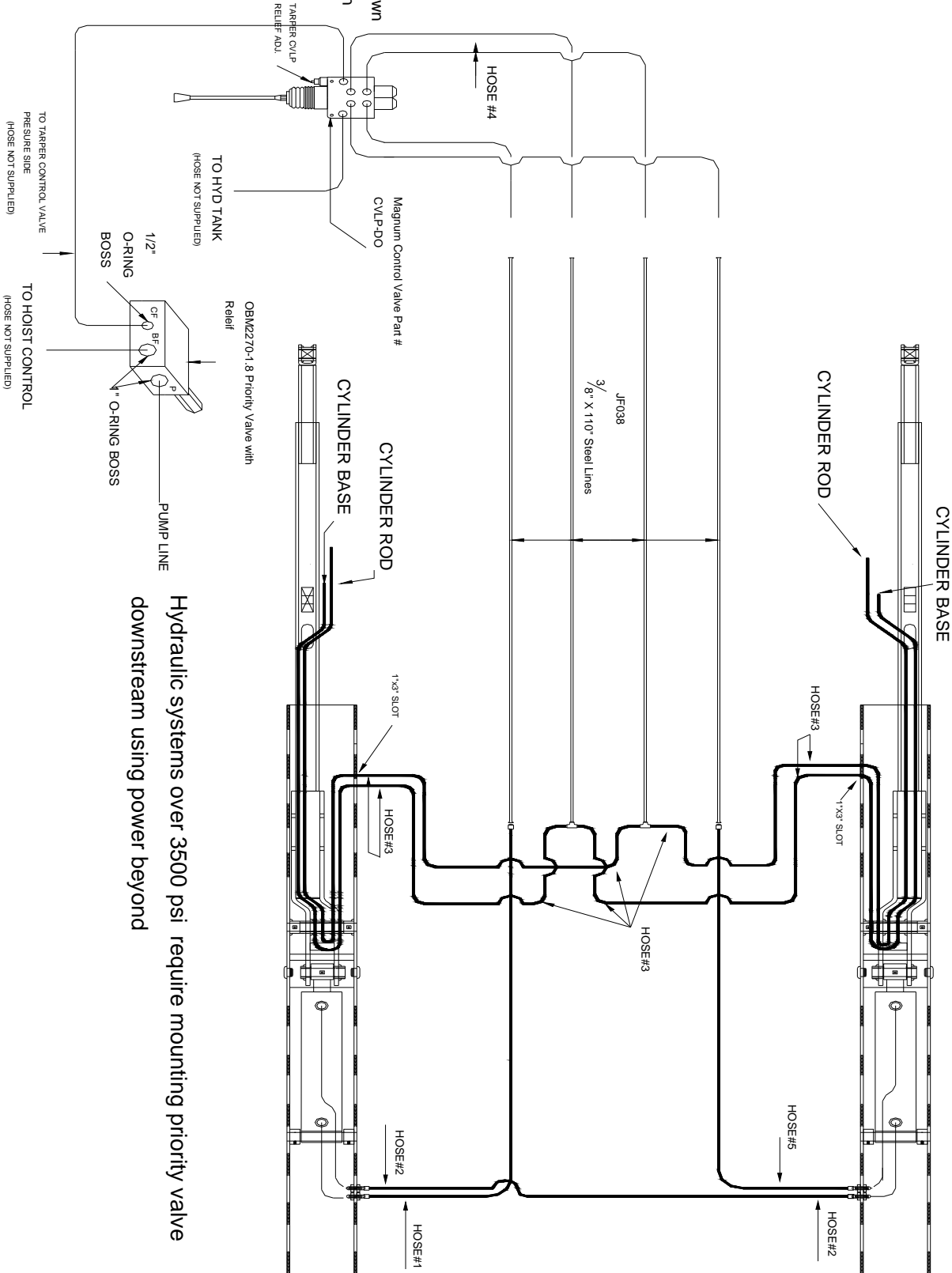

Hydraulic systems over 3500 psi require mounting priority valve downstream using power beyond

MAGNUM-XDG PLUMBING SCHEMATIC

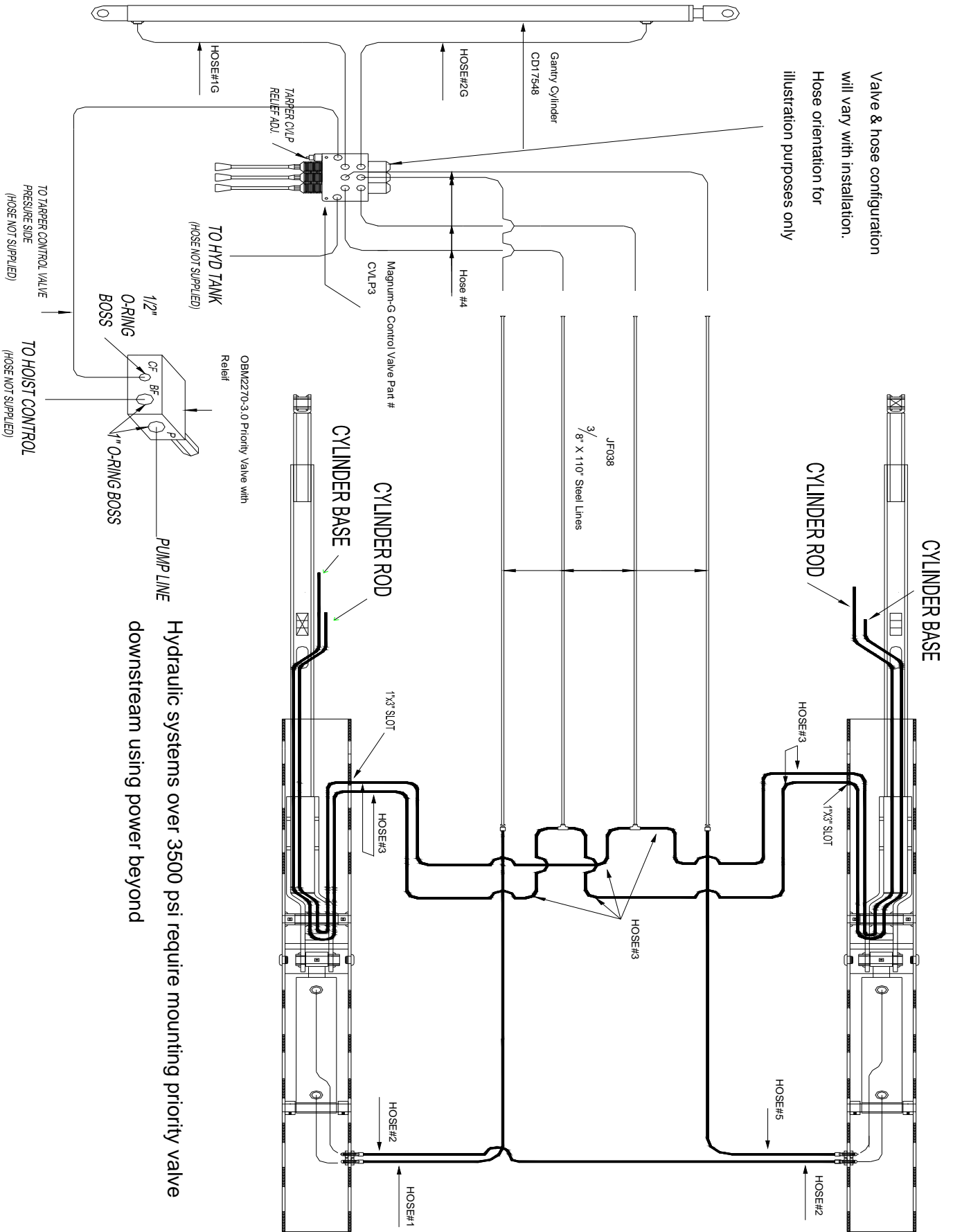

Valve & hose configuration will vary with installation. Hose orientation for illustration purposes only

Hydraulic systems over 3500 psi require mounting priority valve downstream using power beyond

Plumbing Instructions

1. Mount the tarper control valve where it is easiest for the driver to operate. Ideally, it should be located at the rear corner of the cab, positioning the driver out of the way of the tarper arms when operating. Mounting plate and tubing not provided due to varying ways that this can be mounted.
2. Mount the priority valve at a place that is easily accessible for hydraulic lines and maintenance.
3. Disconnect the pump line from the hoist control valve.
4. Plumb the pump line into the 1" O-ring port labeled "P".
5. Fabricate a hose and plumb from the 1" O-ring port labeled "Bypass Flow" back to the hoist control valve, pump port where the hose was removed in step 3.
6. Fabricate and plumb a hose from the ½" O-ring port labeled "Orifice-CF" to the relief valve side of the tarper control valve. The 3/8" male JIC x ½" O-ring hydraulic adapter is in the hose kit bag for this port.
7. Fabricate and plumb a hose from the return port of the tarper control valve back to the tank. The 3/8" male JIC x ½" O-ring hydraulic adapter return port hydraulic adapter is in the hose kit bag.

Upper & Lower Arm Plumbing Instructions

1. Install the 2, 3/8" Tee's onto one end of 2 of the 4, 3/8" steel lines.
2. Route the 4, 3/8" steel lines down the chassis in a neat manor. Be sure that the lines clear anything hanging under the hoist, hoist props, etc. that may hit or bend the lines.
3. Once the steel lines are properly routed, install the weld/plastic tabs to secure the 3/8" steel lines to the frame cross members, subframe, etc. with the T's toward the rear of the truck (See Diagram). You may have to fabricate your own cross member(s) to mount the weld tabs to.
4. Install the 4, ¼" male JIC x ½" O-ring adapters to into the control valve work ports.
5. Route the 4, #4 hoses from the control valve work ports to the 3/8" steel lines. Leave the hoses unconnected for now.
6. Route the #1Hose from the driver's side steel line without a 3/8" Tee, under the chassis and back to the rear bulkhead fitting (closest to the bumper) on the driver's side module. **Tighten the hose fitting down finger tight and ½ a turn. Any more than that will damage the seat in the hose fitting.**
7. Route the #5Hose from the passenger side steel line without a 3/8" Tee to the forward bulkhead fitting (closest to the cab) on the passenger side pivot module. **Tighten the hose fitting down finger tight and ½ a turn. Any more than that will damage the seat in the hose fitting.**
8. Route the #2Hose from the front bulkhead fitting (closest to the cab) on the driver's side to the rear bulkhead fitting (closest to the bumper) on the passenger side. (Yes, this connects the two pivot modules together in series!) **Tighten the hose fitting down finger tight and ½ a turn. Any more than that will damage the seat in the hose fitting.**
9. Install the 4, ¼" male JIC to ¼" O-ring 90 degree adapters into the work ports of the upper arm cylinders
10. Slide 2 of the #3Hoses from the upper cylinders, into the slot and through the arm and out over the main pivot. Take two of the shorter Pro-Tec sleeving pieces and slide them over each hose where the hose enters the upper arm at the cylinder. Install one hose to each adapter on the cylinder, it doesn't matter which one
11. Pull the hoses at the rear to take up the slack. Leave the hoses slack enough so that they are not cut at the slot. At this point, one hose will be longer than the other, MARK IT! This will be the hose going to the base port of the upper cylinder.
12. Take two of the longer Pro-Tec sleeving pieces and slide them over the hoses, feeding them over the main pivot and into the arm
13. Route the hoses around the main pivot, forward and through the 1"x3" slot at the front of the module. Take two of the shorter Pro-Tec sleeving pieces and slide them over the hose to protect it as it comes out of the slot.
14. From there, route the hoses along the forward support bracket, under the frame and to their respective tees. The longer hose will go to one Tee, the shorter hose will go to the other Tee.
15. Repeat steps 10-14 for the other side, making sure that you match the longer hoses to the same Tee, shorter hoses to the same Tee.

- 16 The lower cylinders MUST be fully retracted in order to bleed the cylinders of air. DO NOT extend the cylinders until fluid has completely filled all hoses and cylinders!**
- 17 Start engine and engage the PTO.
 - 18 With the #4 hoses from step 5 being loose, aim them into a bucket.
 - 19 Push the joystick lever "UP" like you are rotating the tarper to the rear of the truck and note which hose spurts out oil
 - 20 Install that hose to the steel line on the outside of the driver's side
 - 21 Push the joystick "DOWN" like you are rotating the tarper from the rear to the front, note which hose spurts out oil
 - 22 Install that hose to the outside, passenger side steel line
 - 23 Push the joystick "LEFT" like you are trying to straighten out the upper arm and note which hose spurts out oil, install that hose to the passenger side, inside steel line.
 - 24 With the remaining #4 hose, install that hose to the driver's side inside steel line.
 - 25 With all the lines installed and tight on the lower cylinder circuit, push the joystick lever DOWN to retract the lower cylinders. If the arms start to rotate, STOP and switch hoses at the outside steel lines.
 - 26 Continue pushing DOWN on the control valve for 3-5 minutes. This will allow the oil to fill the passenger side cylinder, pressurize the re-phasing port and bypass around the seals filling the crossover hose and then driver's side cylinder back to the tank. DO NOT crack lines to bleed this part of the hydraulic system.
 - a. It is normal for there to be squealing, odd sounding noises coming from the cylinders during this process
 - b. Set a timer on your phone for 3-5 minutes to be sure that you fully bleed this circuit!
 - c. It is very important that all of the air is bled out of the lower cylinders. If the arms do not operate together, repeat the bleeding process
 - 27 Disconnect the base port hoses from the upper arm cylinders.
 - 28 Have someone aim the hoses into a bucket
 - 29 Push the joystick lever RIGHT
 - a. Once clean, non-aerated oil comes out, center the joystick and reinstall the hoses to the base port
 - 30 Reengage the valve and push the lever RIGHT, this will extend the upper arm cylinders.
 - a. Hold this position until the cylinders are fully extended
 - 31 Remove the hose from the rod end port of the upper cylinders
 - 32 Push the lever LEFT
 - a. Once clean, non-aerated oil comes out, center the joystick and reinstall the hoses to the rod port
 - 33 Reengage the valve and push the lever LEFT, this will retract the upper arm cylinders.
 - a. Fully retract the cylinders and remove the plastic zip tie holding the cylinder up
 - 34 Extend the cylinders to align the rod end port with the lower pivot point of the upper arm
 - 35 Once aligned, install the LP9 cylinder pin. This is the pin that is 1" x 3" with a ¼" hole located in the center of the pin
 - a. Spraying the pin and bushing material with WD-40 or similar will make assembly MUCH easier
 - b. Align the hole in the pin with the hole in the cylinder rod.
 - c. Install the ¼"x 2 ½" bolt into the hole, ideally with the threaded part of the bolt on the bottom of the cylinder. Secure with the ¼" locknut
 - d. Repeat for the other side
 - 36 Using the provided zip ties, secure ALL of the hydraulic hoses to prevent them from becoming damaged. Place special attention to the hoses between the chassis at the steel lines, where the hoses go under the chassis and securing them to the L-Brackets.
 - 37 With all of the hoses attached and secured, push the joystick valve UP to rotate the tarper from the front to the rear.
 - a. If the lower arms do not lift together, STOP!
 - b. Push the joystick lever DOWN for 3-5 minutes to make sure all of the air is out of the lower circuit

- c. If after doing this and no changes, push the joystick RIGHT to rotate the tarp roller out of the tray so that the tarp arms are fully supporting the tarp roller.
 - d. Push the joystick lever DOWN for 3-5 minutes to make sure all of the air is out of the lower circuit
 - e. If still lifting out of sequence, call O'Brian Tarping Systems technical support at 800-334-TARP (8277)
- 38 Fully rotate the tarp system to the rear of the truck
- 39 Push the control valve RIGHT to fully retract the upper arms and then push the control valve LEFT to fully extend the arms
- a. Repeat this process 5-8 times
- 40 Once the upper arms have been fully cycled 5-8 times, push the joystick lever DOWN to rotate the tarp system back to the front
- a. Pay special attention to the upper arms, if they drift towards the cab once the arms pass center, air is still in the upper arms and will need to be rebled
- 41 Fully rotate the tarper from front to rear and rear to front 5-8 times
- 42 Reposition the tarp roller back into the cradle
- 43 Install the loose decals located in this manual per diagram
- 44 Grind your welds smooth, touch up paint where needed, zip tie any remaining loose hoses, zip tie the Pro-Tec sleeving to the hoses themselves, check for any hose leaks

Maintenance

- 1 Rephase the lower cylinders if the arms get out of sequence
- 2 Rephase the lower cylinders for 2-3 minutes every 2-3 months as part of your maintenance plan. This puts clean, filtered oil back into the lower cylinder circuit for longer cylinder seal life.
- 3 If the tarper arms will not rotate, extend or retract, check that the tarp system pressure is set at 2,200 PSI. This can be done by using the gauge port on the Priority Valve. The Gauge Port is beside the "G" stamping and is a ¼" O-ring port.
 - a. If there isn't enough pressure, adjust the set screw at the relief valve of the tarper control valve by turning the set screw clockwise in quarter turn increments.
 - b. If you go 2 full turns without the pressure increasing, return the setscrew to the initial setting
 - c. Adjust the set screw at the relief valve for the Priority Valve by turning the set screw clockwise in quarter turn increments
 - d. If you go 2 full turns without the pressure increasing, return the setscrew to the initial setting
 - e. At this point, the truck's PTO may be going out as the tarp system requires more pressure than the hoist to operate (2200 PSI versus 1800-1900 PSI to operate)
- 4 Check for hose abrasion on a monthly basis. Repair as needed
- 5 If the tarp will not roll all the way up, add additional tension to the tarp roller. Do NOT add more than 5 additional turns to the tarp roller or spring damage may occur
- 6 Inspect the pivot points for wear/slop on an ANNUAL basis. Replace the self-lubricating bushings as needed
- 7 If the cover rolls to one side when rolling up
 - a. Arm is bent, straighten or replace arm
 - b. Gantry is not plumb with the chassis, straighten gantry
 - c. Pivot assembly is not parallel with the chassis, realign pivot assembly
 - d. Lifting cylinders have air in the system or cylinder is bypassing, rephase lower cylinders or rebuild/replace them.
 - e. Cover not square. Pull additional tarp under tarp bar from slack side, screw tarp to tarp bar and reattach tarp bar to cradle.

DECALS

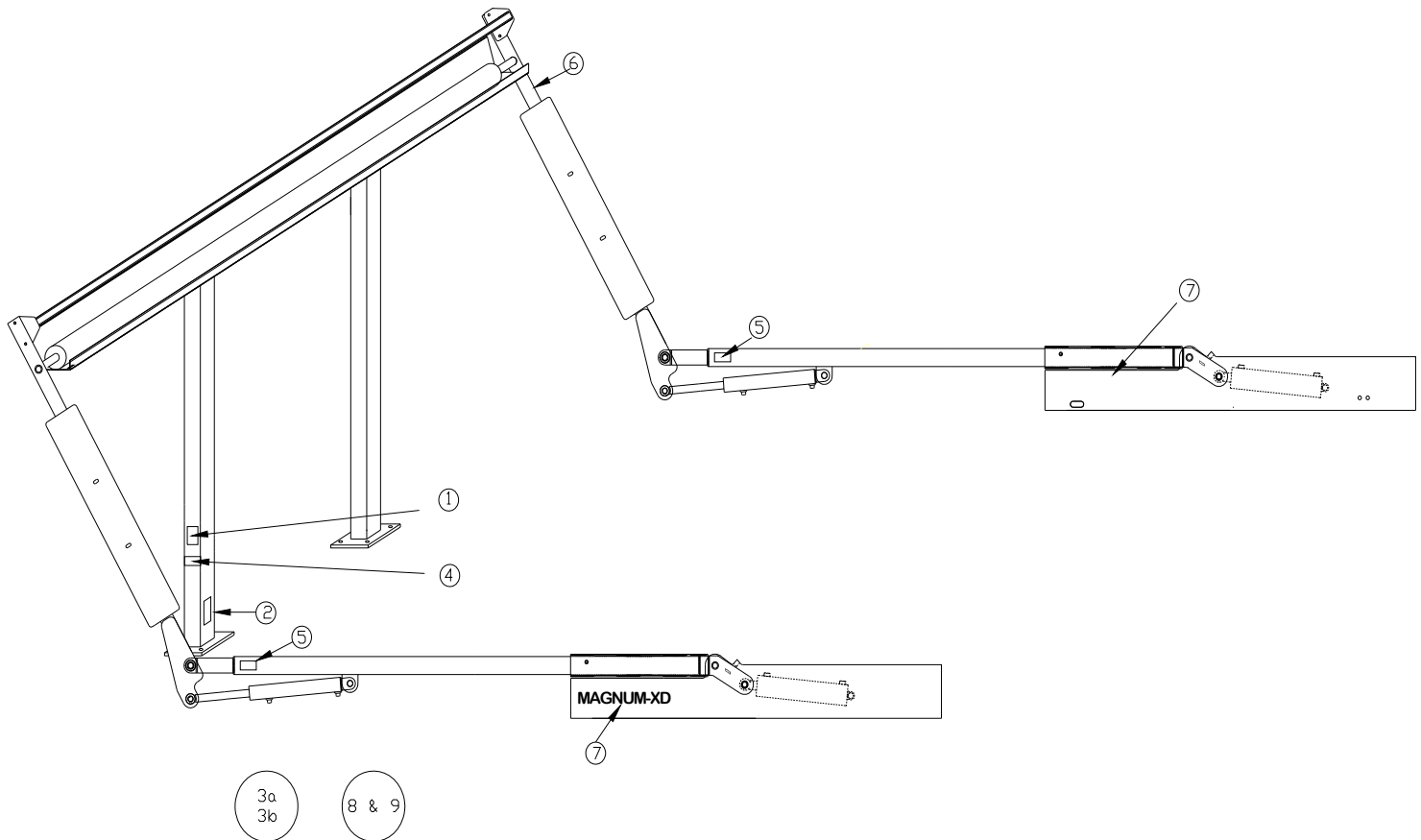

Item#	Part#	Description	Quantity	Location
1	UD13	Electrocution warning	1	Lower gantry, driver's side
2	Serial#	Serial number plate	1	Lower gantry, driver's side
3a	Label operate 5	Joystick operation	1	Near control valve
3b	Label operate 6	3 spool valve operation	1	Near control valve
4	Rephase	Rephase instructions	1	Lower gantry, driver's side
5	Warning	Pinch point warning	2	Middle arm near elbow, both sides
6	RTC	Roller spring tension	1	Passenger side upper arm near tarp roller
7	Magnum	Magnum-XD decal	2	Pivot module, outside, both sides
8	Hanger	Driver operation hanger	1	Place in cab
9	Manual	Owner's manual	1	Place in cab

TARP REPLACEMENT

OPTION 1 will require the purchase of TARP WRENCH, Part# "LW" from O'Brian Tarping Systems

1. Without a box on the hoist, operate the tarp system and extend the roller out to its lowest and farthest position with the roller about four feet off the ground.
2. Clamp the tarp to the hoist or fenders
3. Extend the upper arms which will roll the remaining tarp off the roller. Once you see the bolts that attach the tarp to the roller, stop.
4. Slide the TARP LOCKING WRENCH over the bearing and into the slot on the end of the roller
5. Slowly retract the upper arms until the Tarp Locking Wrench handle is engaged against the stabilizer bar. Continue to retract the upper arms until the tarp roller is close to the ground.

6. Remove the 5/16" x 5/8" bolts from the tarp roller and the two 5/16" x 2" bolts attaching the tarp bar to the cradle
7. Discard the old tarp. Spread out the new tarp onto hoist with the O'BRIAN logo up, flaps down with the logo on the driver's side, close to the cradle.
8. Re-insert the tarp bar into sleeve of tarp. Center the tarp on the tarp bar and re-attach tarp bar to Cradle.
9. Attach rear of tarp to Roller with the 5/16" x 5/8" bolts and washers. Make sure the tarp is centered.
10. Pull the tarp to the rear of the truck and reattach the tarp to the hoist/fenders as in step 2
11. Extend the upper arms until the tension on the tarp releases the tension on the tarp wrench. Remove the tarp wrench,
12. Retract the upper arms til the tarp roller is back close to the hoist
13. Remove the clamps holding the tarp to the hoist/fenders
14. Fully extend the tarp system to the rear of the truck
15. Rotate the tarp system back to the front of the truck and place roller in cradle

*****Note*** If spring tension is lost, re-tension roller from the FRONT OF THE TRUCK ONLY!!!!
See pretension instructions on Page 11 and 12. DO NOT TRY TO RE-TENSION ROLLER FROM REAR OF TRUCK AS THE SPRING TENSION AT THE REAR IS TOO GREAT*****

OPTION 2

1. Remove the stabilizer bar, driver's side and passenger side upper arm from the tarp roller.
2. Remove the bolts locating the tarp bar to the cradle.
3. Remove tarp roller assembly and lay it down on the ground. Unroll the tarp roller from the old tarp.
4. Spread new tarp on floor with the O'BRIAN logo up and flaps down beside old tarp.
5. Remove the tarp roller from the old tarp and transfer to the new tarp. Reinstall the 5/16"x5/8" bolts and washers to attach the new tarp to the roller.
6. The passenger side of the tarp roller shaft will have a machined flat spot. Be sure that the passenger side of the roller is on the passenger side of the tarp (opposite end and opposite side of the O'BRIAN logo.
7. Roll the tarp roller over the tarp, rolling up the tarp to the end.
8. Slide the tarp bar into the sleeve of the tarp and position into cradle. Make sure that the tarp is centered left to right.
9. When placing the roller into the cradle, make sure that the sleeve and tarp bar is coming over the top of the roller and attaching to the inside of the cradle
10. Slide the driver and passenger upper arms back onto tarp roller shaft
8. Place the tarp tensioning wheel on passenger side roller spring shaft. Torque set screw against the flat side of RSA shaft. If the flat spot is on the Driver's side, you have the tarp roller on backwards.
9. Install the 5/16" x 1-3/4" bolt and locknut through the passenger side upper arm (MUSA1020-PA) attaching the arm to the tarp roller. You may have to turn the wheel in order to line up the holes
10. Torque the wheel 10-12 turns clockwise **FROM THE PASSENGER SIDE**. Keep turning the wheel until the holes in the arm lineup with the holes in the roller. Finish by placing a 5/16" x 1 3/4" bolt through roller shaft and upper arm on Driver's side. Finish by tightening the 5/16" locknuts against the bolts.

****Failure to install the bolt on the driver's side will cause the ratchet and pawl mechanism to fail, not warranty****

11. Install the stabilizer bar (SAEXLPS) between the upper arms using the (4) 3/8" x 2 1/4" bolts and lock nuts. Make sure that the stabilizer bar offset is facing toward the rear. You may have to push or pull the elbows towards the chassis in order to install the stabilizer bar



MAGNUM-XD
EXCLUSIVE TWENTY-FOUR MONTH LIMITED WARRANTY

O'Brian Tarping Systems warrants products of its manufacturer against operational failure caused by defective material or workmanship, which occurs during normal use within twenty-four (24) months from date of shipment from our factory or in service date with proper documentation. The tarp is NOT covered under warranty.

O'Brian Tarping Systems will rebuild or replace at our discretion, all parts of our manufacturer free of charge that our inspection at our factory shows to be defective in accordance with the above paragraph. WRITTEN PERMISSION MUST BE OBTAINED FROM AN AUTHORIZED FACTORY REPRESENTATIVE FOR ANY REPAIRS PERFORMED OTHER THAN IN OUR FACTORY.

All products purchased by O'Brian Tarping Systems from an outside vendor shall be covered by warranty of that respective vendor only, and O'Brian Tarping Systems does not participate in or obligate itself to any such warranty.

NO FREIGHT, TRAVEL COSTS, MEALS, LODGING, LOSS OF HYDRAULIC FLUID OR TRUCK DOWN TIME SHALL BE COVERED BY THIS WARRANTY. All labor costs allowed shall be in accordance with O'Brian Tarping Systems established labor rates. In case of alleged defect, product shall be returned to O'Brian with transportation pre-paid.

Any service part sold by O'Brian Tarping Systems shall be warranted for thirty (30) days from date of shipment from our factory or in service date with proper documentation. No credit for labor will be allowed under this warranty if the returned part, upon our inspection, proves to be non-defective.

O'Brian Tarping Systems makes no warranty on any of its equipment used in any way except as it was designed, intended and sold to perform.

This limited warranty is expressly in lieu of all other warranties, expressed or implied, and of all other obligations or liabilities on the part of O'Brian, and it neither assures nor authorizes any other person to assure for it any other liability.

O'Brian Tarping Systems does not assume any liability for loss of product, time or any other inconsequential damages. All claims shall be processed through O'Brian Tarping Systems